



Belt-Way Scales, Inc. Conveyor Belt Scale Product Manual

Belt-Way Scales, Inc.
102 Daugherty
Webb City, Missouri USA
Phone: (815) 625-5573
www.beltwayscales.com

8040-0045-0M Rev-B 04/24

This page intentionally left blank



Safety and Warnings



All Belt-Way components **MUST** be used as described in this manual!

Please note the labels on the integrator and in the manual denote dangerous voltage. Failure to take safety precautions may result in serious injury or death.

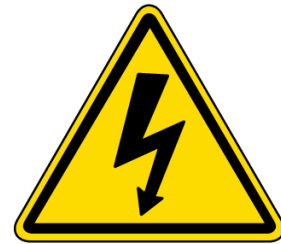

The protective conductor terminal (Earth Ground) is signified by the following label. It must be properly connected to earth ground per local electrical codes.

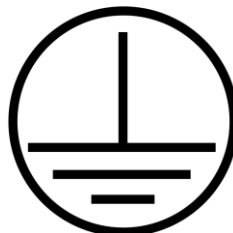
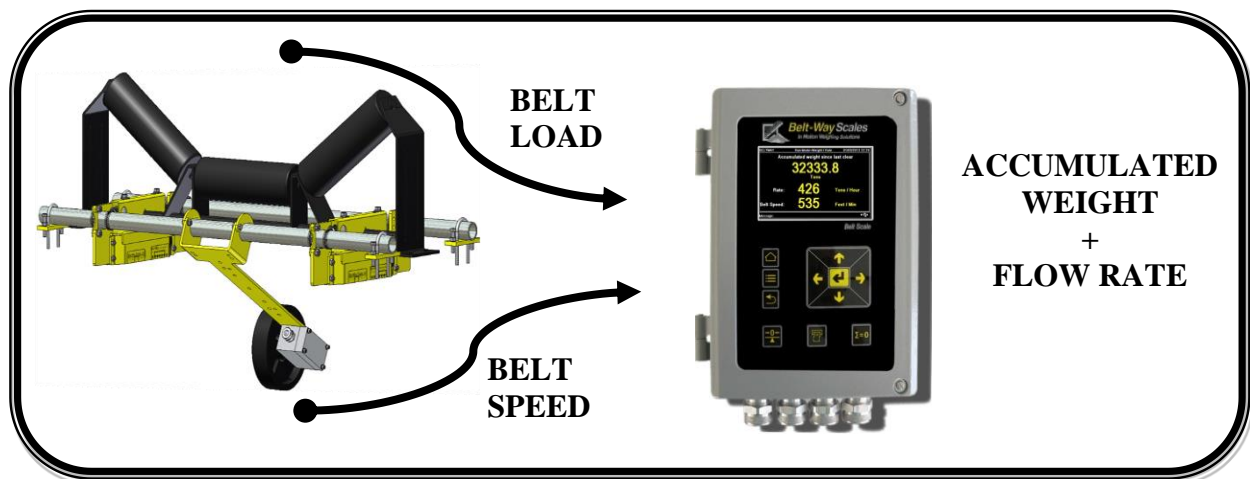

Table of Contents

Scale Accessories	6
Integrator Specifications	7-9
Mechanical Installation.....	10-16
Integrator Installation	17-22
Integrator Board	18
Sensor and Power Wiring	19
Sensor Board	20
Terminal Board with AC Power Supply.....	21
Terminal Board with DC Power Supply.....	22
Integrator Configuration	23-36
Setup Wizard	24-25
Scale Setup	26
Scale Calibration	27
Zero Calibration	27
Test Weight Calibration.....	28-29
Material Test Calibration.....	30
Totals and Diagnostics.....	31-33
Scale Totals.....	31
Scale Diagnostics.....	31
Device Setup.....	34-35
Plant Connect	35
Administration.....	36
Routine Maintenance	37
Troubleshooting	38-39
Calibration Logs	40-41
Product Warranty	42-43

Introduction

The Belt-Way conveyor belt scale is a highly accurate and cost effective in-motion weighing system designed to measure material flow over a conveyor belt in real-time. The primary components are the integrator (AKA, controller, display, indicator), load cell assemblies, and speed sensor. The scale system processes speed and load signals to accumulate weight and calculate flow rate.



This manual covers the following belt scale models:

- Model 45, Model 50 (Low capacity)
- Model 100, Model 150, Model 200 (Medium capacity)
- Model 350, Model 500, Model 1000 (High Capacity)

This manual pertains to scales operating on firmware 6.43 and above.

A manual for previous versions may be found at beltwayscales.com

Scale Accessories

The Belt-Way conveyor belt scale works with a range of accessories designed to maximize accuracy, efficiency, and safety.

Visit beltwayscales.com or call us today for a complete list of all the accessories that Belt-Way has to offer.

- **Angle Sensor**

The angle sensor eliminates the need for constant recalibration when the scale is installed on a variable angle conveyor or portable machine.



- **Junction Box**

A junction box can be installed on the conveyor to place the scale integrator up to 1000 ft. from the scale.



- **IO Board**

The IO board allows the scale to interface with a PLC system, automate loadout of trucks and rail cars, or control a VFD to blend multiple products.



- **Outdoor Protection Enclosure**

Heavy duty enclosure offers extra protection for the scale integrator. Includes power switch.



- **Wireless Multi-Scale Remote Display**

The remote display allows multiple scales to be viewed from one location. Monitor production, clear weight, and perform zero calibrations. Wireless communication makes installation simple and cost effective.



- **Plant Connect - Online Scale Production Reporting**

Our Plant-Connect website allows users to monitor belt scale production on a PC, tablet or smart phone.



Integrator Specifications

Replacement Part Number: BWINT

100-240 AC Power Supply Factory Installed Part Number: BWPS-AC

100-240 AC Power Supply Field Installation Kit Part Number: BWPSKIT

IO Option Board Part Number: BWIO (Factory Installed)

IO Option Board Kit Part Number: BWIOKIT (Field Installed)













Display: 4.3" Color LCD
Enclosure: Cast Aluminum
Operating Temperature: -20°C to 45°C
Required Power: 12-24 VDC, 55 Watts
optional 110/240 AC power adapter
Inputs: 8 Load Cells (millivolts)
1 Speed Sensor (0-5 VDC Pulse)
1 Angle Sensor (0- 4 VDC)
Outputs: 1 RS232 (Printer Port)
1 RS232 (Display Port)
1 Ethernet Port (Modbus TCP)
1 USB 2.0 Client

Optional IO Outputs:
4-20 mA outputs (Tons Per Hour)
Digital Pulsed Output (Total Weight)
Min / Max Speed
Min / Max Tons Per Hour
Zero Calibration
Loadout
Optional IO Inputs:
Clear Weight
Print Ticket
Zero Calibration

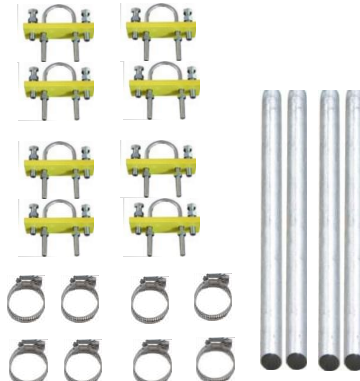
Electrical Ratings	
Input Power to Belt-Way Integrator:	12-30 VDC, 24 VDC 2.25A Max
AC Power option:	Input:100-240VAC 50/60Hz, 1A Max Output: 24VDC, 2.25A Max
<p>Use of the factory supplied AC Power option is recommended.</p> <p>AC control power over-current protection with isolated circuit, and disconnect point such as a breaker or switch box, is recommended. Conformance to local electrical codes is required.</p>	
Digital Inputs: (IO option installed)	12-24VDC, 50mA sink
Digital Outputs: (IO option installed)	12 - 24VDC, 100mA sink
Analog Outputs: (IO option installed)	4-20mA, 24VDC powered loop
Relay Outputs, UL contact ratings: (IO option installed)	220VDC, 0.24A, 60W 125VDC, 0.24A, 30W 250VAC, 0.25A, 62.5VA 125VAC, 0.5A, 62.5VA 30VDC, 2A, 60W
Environmental	
<ul style="list-style-type: none"> ▪ Temperature: Normal operating range -20°C to +45°C. ▪ Humidity: The unit is suitable for outdoor use. ▪ Altitude: The unit is suitable for use to elevation of 2000m. 	

Scale Components

The single idler scale consists of the following components			
1 - Integrator 	2 - Load Cell Assemblies 	2 - Mounting pipes 1- Hardware Kit 	1 - Speed Sensor with mounting arm 
The dual idler scale consists of the following components			
1 - Integrator 	4 - Load Cell Assemblies 	4 - Mounting pipes 2 - Hardware Kits 	1 - Speed Sensor with mounting arm 
Unpacking the Scale Each scale is comprised of at least three boxes			
26" x 10" x 8" - Integrator and Speed Sensor 	26" x 10" x 8" - Load Cells and Hardware kit 		
48", 60" or 72" long boxes for mounting pipe and various sizes for angle sensors and other accessories			

Mechanical Installation

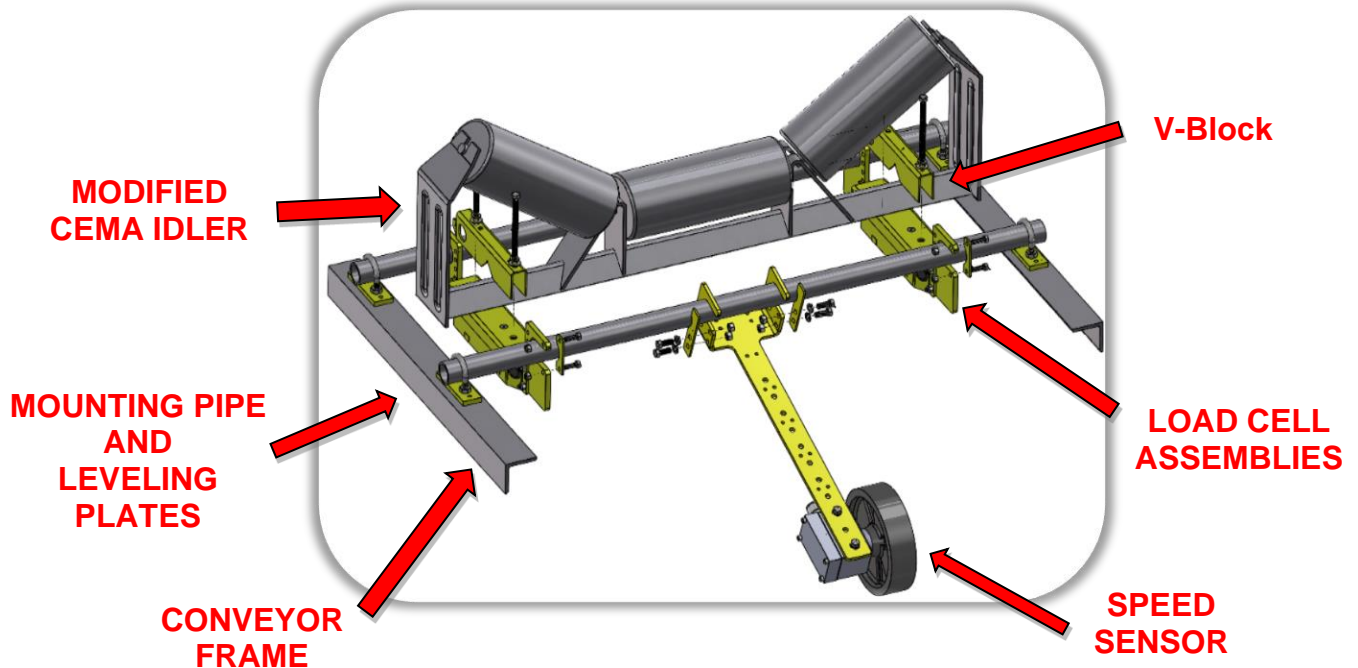

2D component and installation drawings are available at beltwayscales.com
 3D drawings are available by request.

A. Recommended Tools

- **Cutting torch and grinder** (remove idler mounting feet)
- **Heavy duty drill or magnetic drill press** (drill u-bolt holes)
- **Tape Measure** (measure idler distance)
- **Angle finder or phone app** (measure conveyor angle)
- **1/2" socket and wrench** (load cell and speed sensor brackets)
- **9/16" deep socket and wrench** (V-block, u-bolts, leveling bolts)
- **String** (to level weighbridge idlers)
- **Shim kit** (to adjust idler height)
- **4 way screwdriver** (integrator mounting, integrator door, hose clamps)
- **Small Belt-way screwdriver** (integrator wiring)

B. Conveyor Design Recommendations

The following design suggestions are essential for best scale accuracy and repeatability.

- Reduce speed whenever possible to maximize belt load. Slow moving, heavily loaded belts work better than fast moving, lightly loaded belts.
- Proper belt tension must result in 1%-2% deflection between idlers. For example, 2% deflection is 1 inch sag in the belt over a 4 ft. idler spacing.
- Lower trough angles, 0°-35°, are preferred. Avoid 45° troughed idlers.
- Install a belt scraper to keep the belt clean.

- Cover the conveyor to shelter it from wind, rain and snow.

C. Scale Placement

- Install the scale where it is easily accessible for maintenance purposes.
- Choose a very rigid section of conveyor such as an idler over a brace.
- Avoid curves in the conveyor.
- Stay at least three idlers away from the head pulley, tail pulley, and loading points.

Material must not impact the belt near the scale!

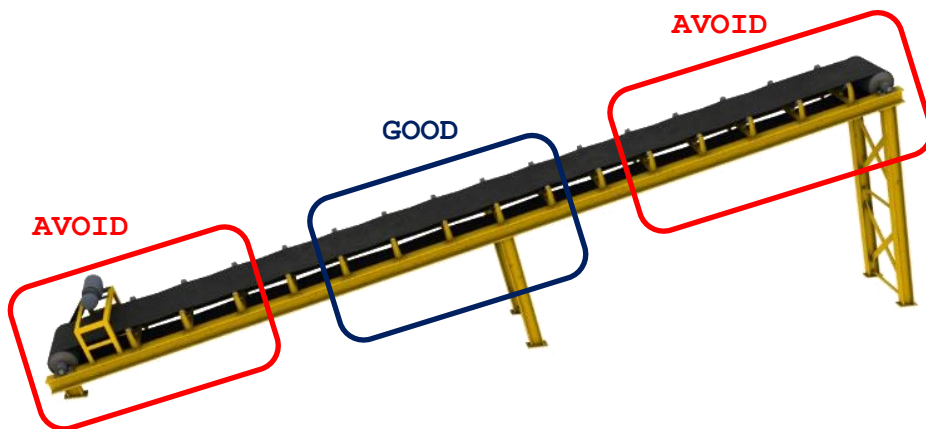

D. Define the Weighbridge

- The weighbridge idlers must be in good mechanical condition.
- The weighbridge idlers must be the same trough angle, and diameter.
- The weighbridge idlers should be an equal distance apart.
- Skirting should not make contact with the belt in the weighing area.
- A single idler weighbridge consists of 5 idlers.
Scale must be installed on the center idler
- The dual idler weighbridge consists of 6 idlers.
The scale must be installed on the 2 center idlers.

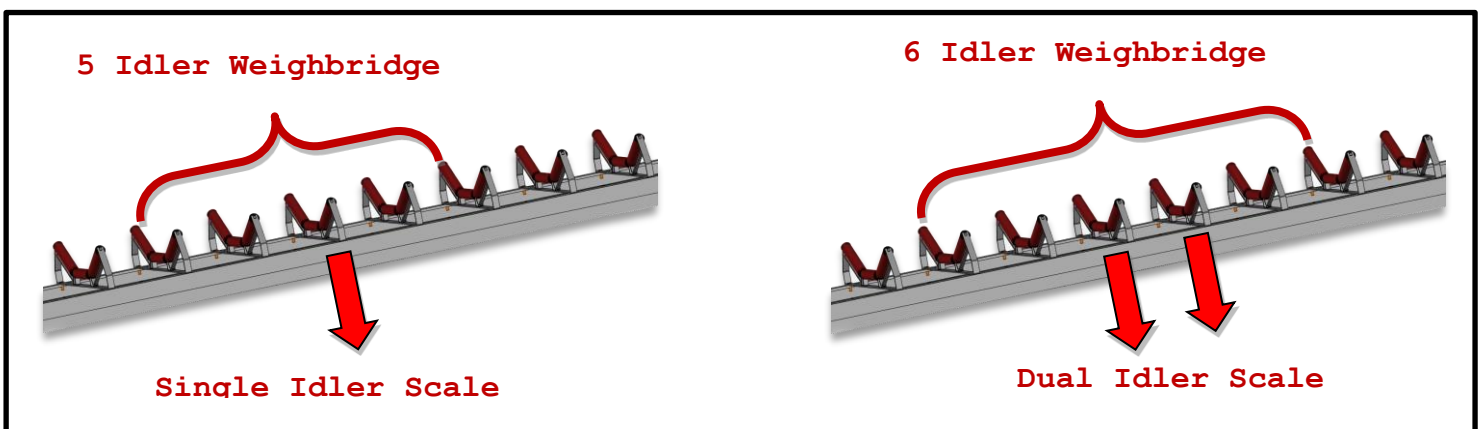

E. Attach Load Cell Assemblies to idler

- Bolt the load cell assemblies to the idler as shown using the V-Block.
- The load cell cable should point downhill.
- Leave plenty of clearance between the load cell assembly and conveyor frame.
- Do not overtighten the V-Block bolts.
- The bolts should be tightened $\frac{1}{4}$ turn after compressing the lock washer.
- Position the load cell assemblies an equal distance from the conveyor frame.
- This balances the load of the belt evenly between the load cells.

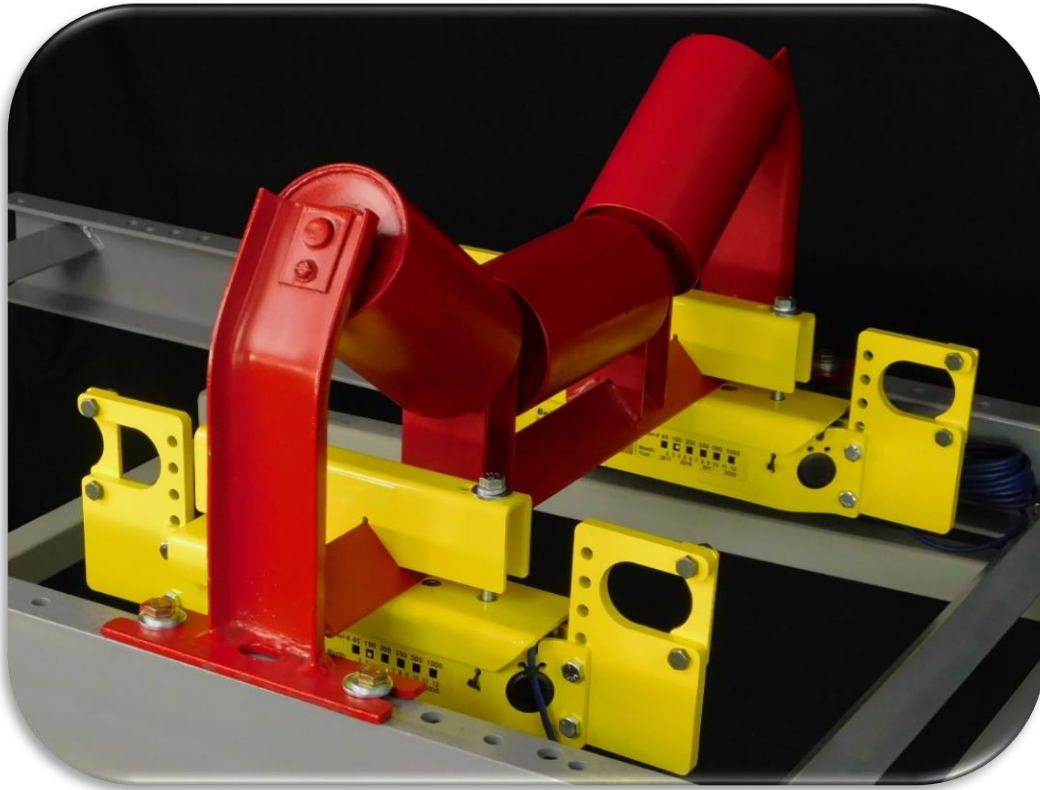

NOTE: Stainless Steel Load Cells – Do not use a full thread bolt, or over tighten the existing V-Block bolt on a stainless steel load cell. This will damage the load cell cable.

F. Install Scale Support Pipes

This step is extremely important to ensure long term scale accuracy.

- The mounting pipe must touch the strap on the uphill side of load cell assembly.
- The strap on the downhill side must create an oval opening.
- Center the pipe in the oval hole.
- The load cell assembly must be free to move up and down slightly on the pipes. This eliminates torque on the conveyor frame, which allows automatic alignment of the weighing elements.
- Install the four hose clamps onto the pipe with the screw fitting directly over the top of the pipe, but do not tighten the clamps at this time.

**Uphill side:
Retaining strap
fits tightly around the pipe.**



**Downhill side:
Retaining strap
forms oval hole around the pipe.**



G. Drill U-bolt Holes

- Use the leveling plate as a drill template for the U-bolts.
- The centers of the leveling plates and pipes should measure 15" apart.
- The holes should be at least 7/16" to clear the 3/8"-16 U-bolts.

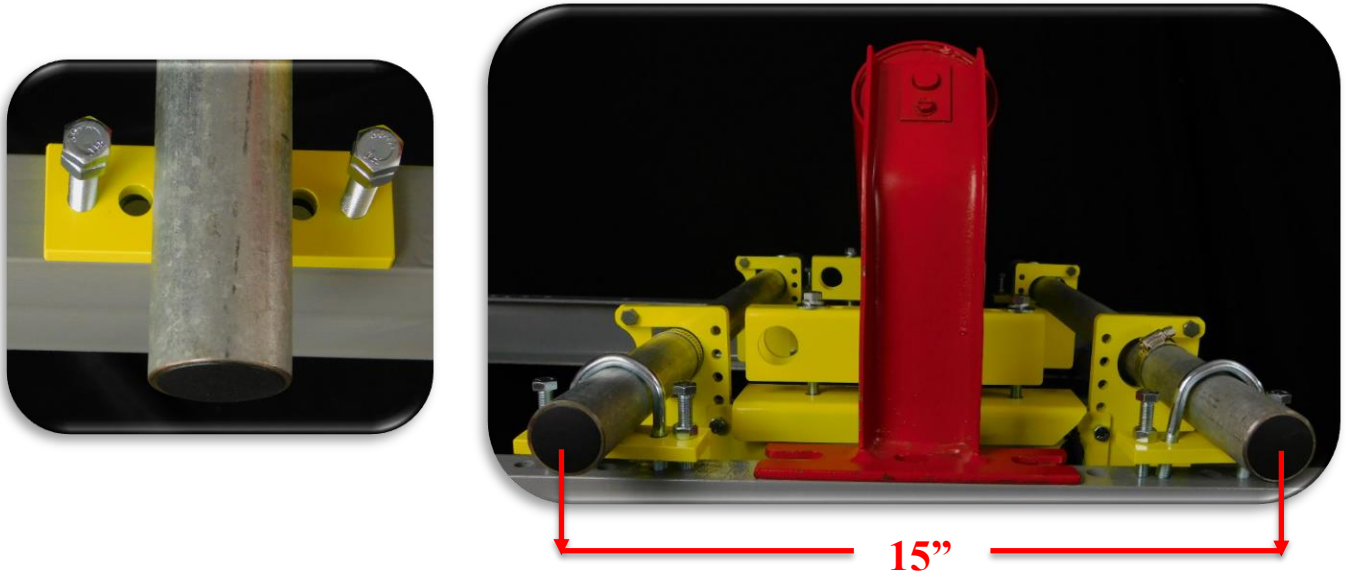

H. Remove and Modify Idler

- Unbolt idler from frame.
- Remove the idler mounting feet to create clearance above the conveyor frame.
- If the idler feet are not removed, all other weighbridge idlers must be shimmed up 3/8".
- Ensure the idler is centered on the conveyor.

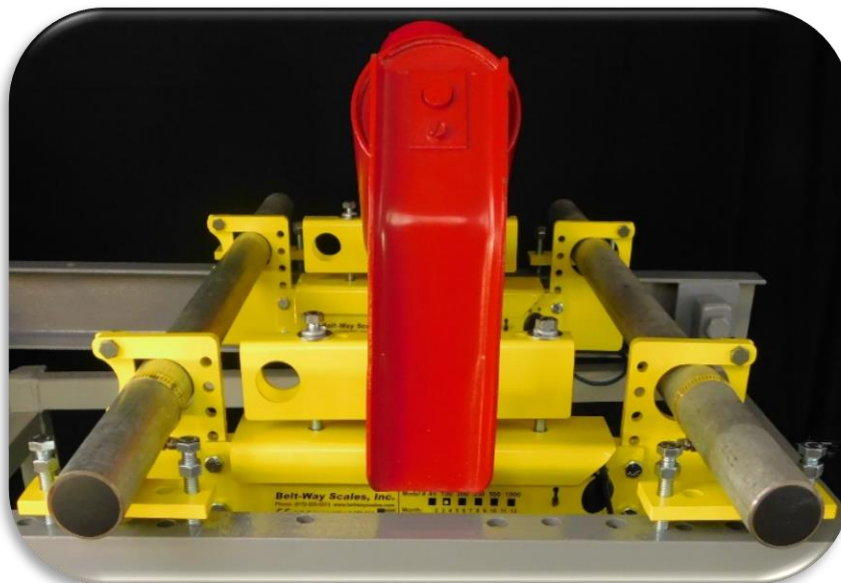

I. String-Line Idlers to level the Weighbridge:

This is an extremely important step in the installation process.

- The empty belt must rest uniformly on all idlers within the weighbridge.
- Use a minimum of three strings to align all 5 or 6 weighbridge idlers.
- Shim idlers if necessary to bring them into alignment.

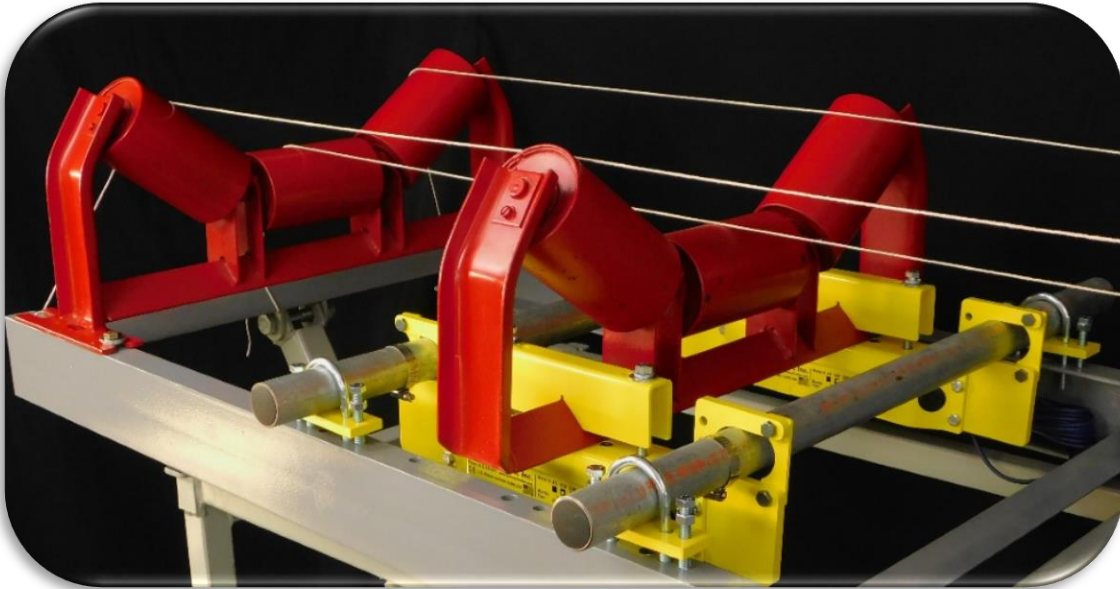

- Use the 3/8-16 leveling bolts to adjust the scale idler height
- Tighten U-bolts evenly so pipes remain parallel and oval clearance around bottom pipe is maintained.
- Tighten the jam nuts against the leveling plate to lock the pipes in place.

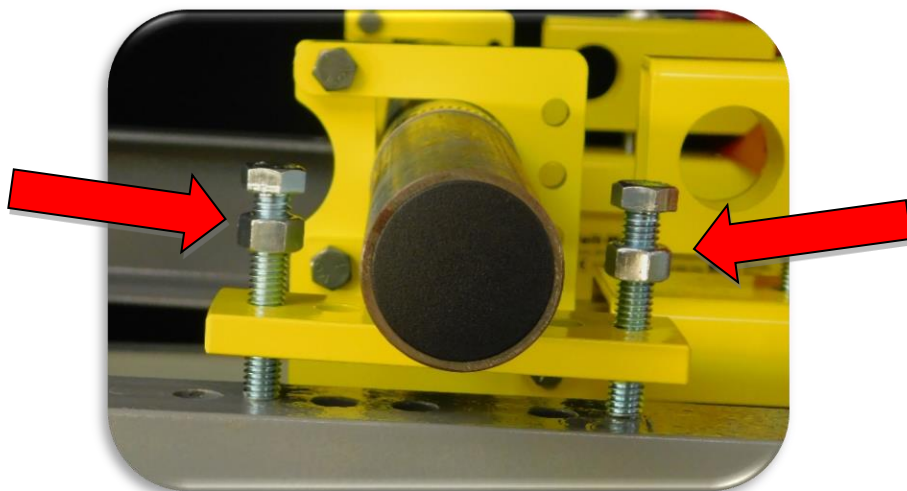

J. Install Hose Clamps:

- Install the hose clamps on the outside of the load cell assembly.
- Leave clearance so the clamps don't bind between the pipe and load cell bracket.
- Rotate the screw barrels away from the gaps between the hanger brackets and the pipes.



K. Install Speed Sensor Assembly

- The standard speed sensor assembly may hang from either pipe. It must point downhill.
- The wheel must ride smoothly on the belt.
- Avoid installing it near return idlers that may cause the wheel to bounce.
- A small amount of weight may be added to the speed wheel arm to hold the wheel firmly on the belt.
- Use two hose clamps to retain the mounting arm.
- Secure the cable to the arm with cable ties. Route the cables carefully along the conveyor frame so they are protected from falling debris and pinch points.

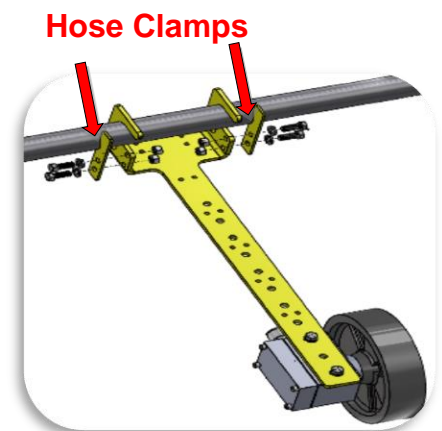

L. Optional Angle Sensor

Any conveyor that frequently changes angle must have an angle sensor installed.

- Mount the Angle Sensor directly on the conveyor frame.
- Mount in the direction of the head pulley.
- Reference the UP arrow indicator on the sensor.



Caution: Excessive vibration will interfere with Angle Sensor performance.



WARNING!



Always disconnect power before servicing the integrator!

Make sure you **LOCK OUT, TAG OUT** and **TRY OUT** the electrical system before any maintenance or service. Please follow all Federal, State and Company Safety procedures and policies when working with this product.

Integrator Installation

The mounting kit includes four mounting feet and four M6 x 1mm x 60mm screws with nuts to attach mounting feet to the Integrator. Customer must supply fasteners from mounting feet to mounting location. Leave a minimum of 3" clearance on the hinge side to allow the door to open.

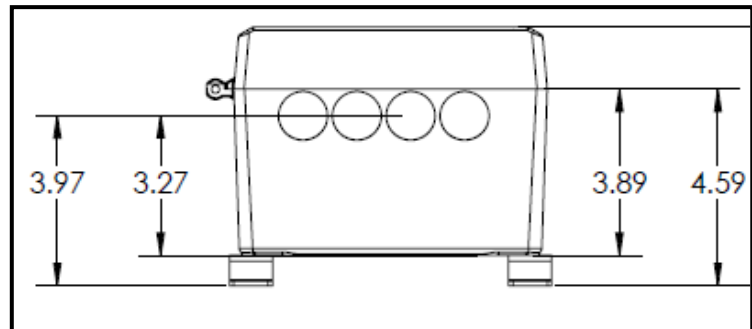
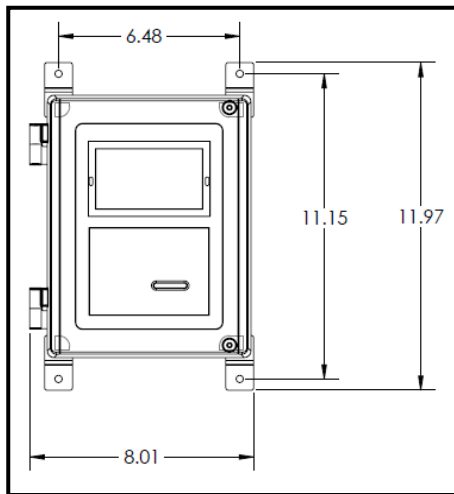

The integrator is weatherproof but should be installed in a protective enclosure whenever possible.

Physical damage to the integrator is not covered under warranty.



Do not install the integrator where it is subject to vibration.

Damage from vibration is not covered under warranty

Rubber or neoprene should be used to dampen the effects of vibration. This is especially important on portable machines. Vibration Mounting Kits are available from Belt-Way.

Order part number **BWVIBRATIONMT**.

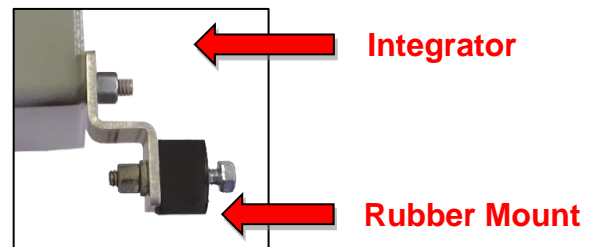

A. Integrator Board

The scale firmware and programmable settings are stored in the integrator board.

MAKE SURE THE USB IS INSTALLED BEFORE PROCEEDING WITH SCALE SETUP.

The scale will function without the USB but it records Important calibration and operating data.

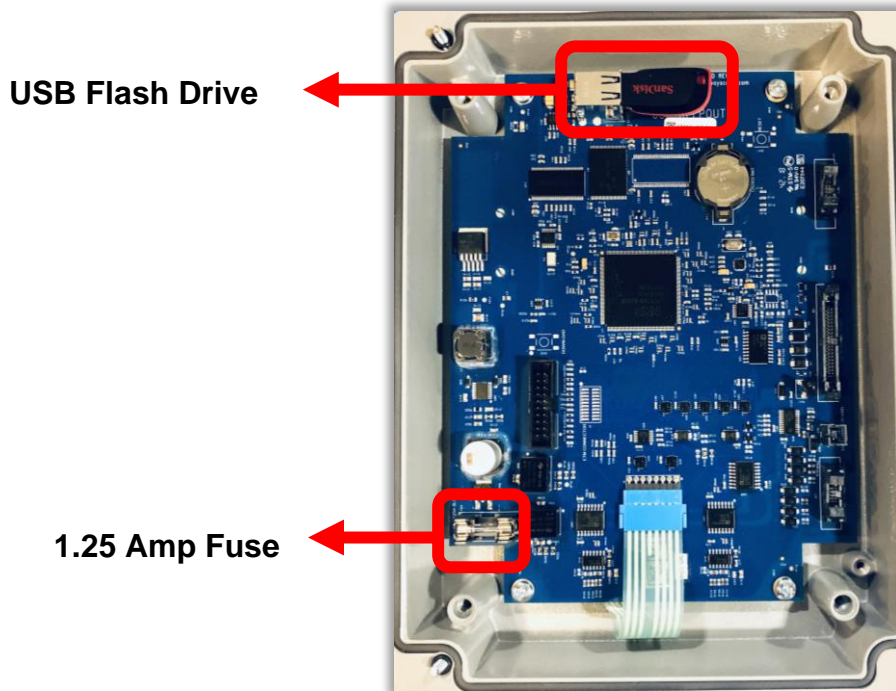

The door pouch includes a test report and power over ethernet fuse for the terminal board. The fuse should be installed only when the integrator is connected to a wireless transmitter.



B. Wiring the scale sensors and power

Use a small screwdriver to carefully remove each connector.

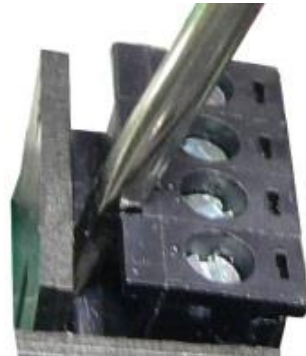

Shield Wire Grounding

Load Cell, Speed Sensor, and Angle Sensor wires **MUST** be connected as shown below. Properly terminating the shield wire is required to reduce electrical interference. Route the cable through the rubber grommet and loop the shield wire back out so it touches the aluminum connector.

Cord Connector →

Rubber Grommet →

Shield Wire →

Connector Cap →

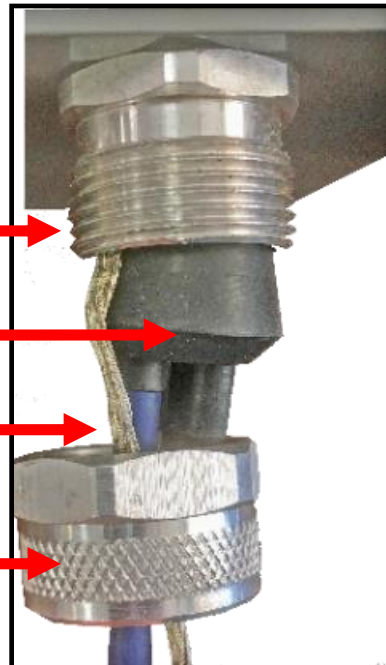

C. Sensor Board

Load cells, the speed sensor, and angle sensor connect to the sensor board.

.80 A Fuse

Speed Sensor Wiring
SIGA – GREEN
+5V – RED
GND – BLACK & WHITE

Angle Sensor Wiring
SIG – GREEN
GND - WHITE
+5V – RED
GND - BLACK

Load Cell Wiring
-SUP – BLACK
+SUP – RED
-SIG - WHITE
+SIG – GREEN
USE LC1 - LC2 FOR SINGLE IDLER SCALES
USE LC1 - LC4 FOR DUAL IDLER SCALES

D. Terminal Board with 110 / 240 AC Power Supply

**All power wiring must conform to local and national electrical codes.
Always disconnect power before servicing the integrator.**

The AC Power supply is installed below the Sensor Board. It converts 110/240 AC to 24 VDC.

Ethernet Port
Power Over Ethernet 1.25 A Fuse
Only install this fuse when using a wireless transmitter!

110 AC - To Power Supply

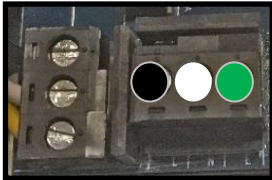

LINE - BLACK
NEUTRAL - WHITE
EARTH GROUND - GREEN

The user must supply a minimum 16-gauge 3 wire power cord.

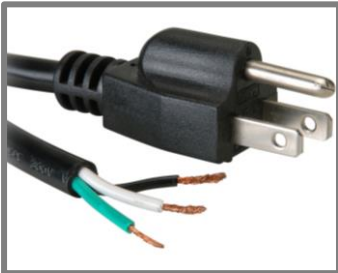

Connect to a properly grounded receptacle that is rated for at least 15 Amps at 110 VAC.

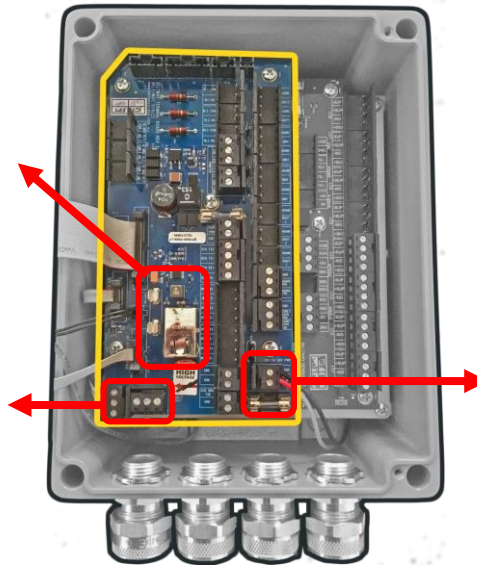

24 VDC From Power Supply

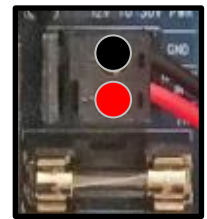

GND = BLACK
+24V = RED
6 A Fuse

Ferrite Bead Installation

Each scale includes a ferrite bead to meet CE emission requirements.

Run all AC wires through it as shown to the right.

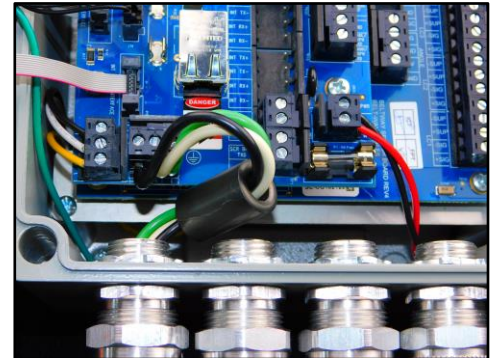

NOTE FOR GENERATOR POWER

A generator may produce unstable power during the startup or shutdown sequence.

The integrator is sensitive to power fluctuations and should be disconnected at startup and shutdown to prevent data loss. Use a breaker or simply unplug the power cord from the outlet until the generator is fully powered up.

E. Terminal Board with DC Power Supply

The DC Power supply is installed below the Sensor Board.
It boosts 9-24 VDC up to 24 VDC and regulates the voltage during engine cranking.

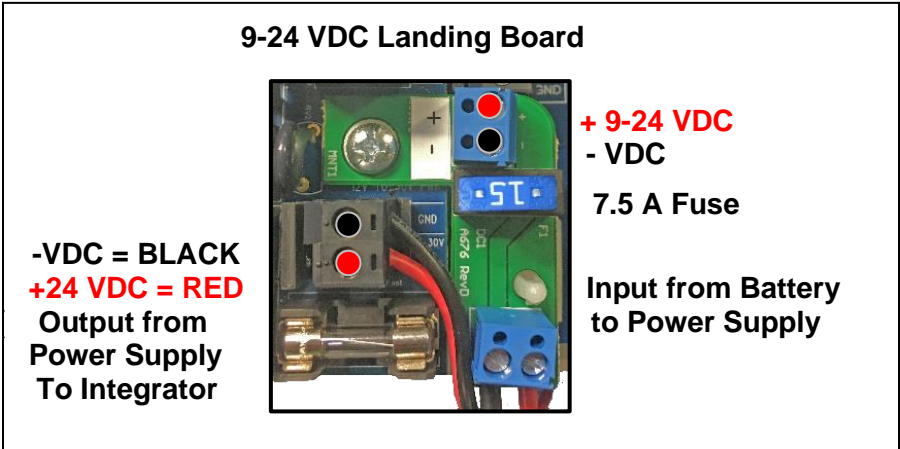

User should supply a toggle switch to isolate the integrator from the battery.

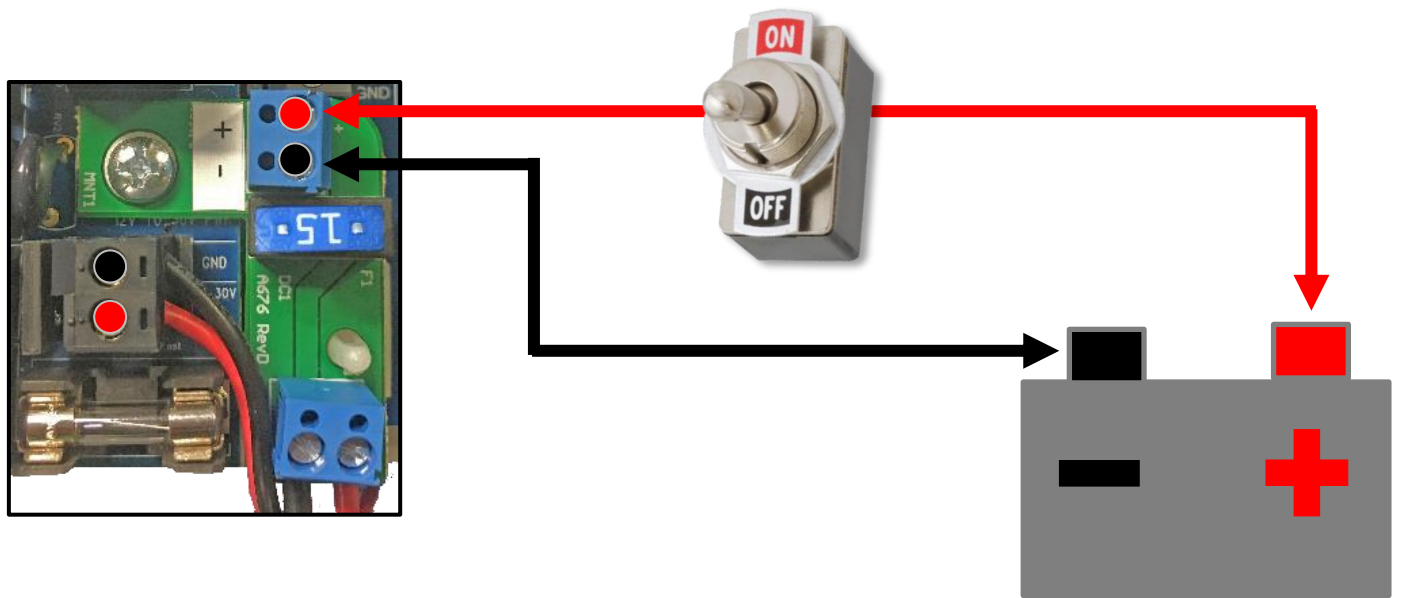

Integrator Configuration and Scale Calibration

A.Integrator Navigation and Data Entry



HOME: Returns to the **Run Screen**



MAIN MENU: Displays the **Main Menu**



BACK: Moves to previous screen only



ZERO CALIBRATION: Initiate the **Zero Calibration** process



PRINT TICKET: Print ticket or save a screenshot to USB when no printer is installed.



CLEAR WEIGHT: Press **TWICE** to reset the accumulated weight to 0.



ENTER KEY (Middle Arrow): Press to select menu options or accept value changes.



ARROW KEYS: Use to navigate menus.

Editing Numeric Values

Various integrator functions require the user to edit numeric values: (Idler distance, test weight calibration, IP address etc.)
When prompted, use the arrow keys and follow the on screen instructions.

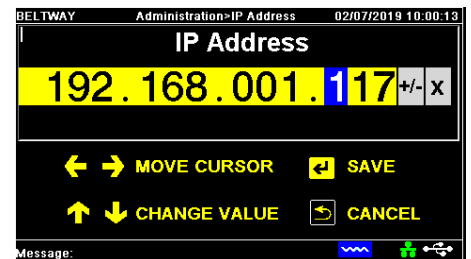

Editing Alphanumeric Values

Various integrator functions require the user to edit alphanumeric values: (scale name, password, etc.)

Use the arrow keys to highlight desired letter and press **Enter** to select. When the word is complete,

1	2	3	4	5	6	7	8	9	0	Esc
A	B	C	D	E	F	G	H	I	J	Del
K	L	M	N	O	P	Q	R	S	T	←
U	V	W	X	Y	Z	,	-	.	@	&

use the virtual enter button to save.

Virtual Enter Button

B. Setup Wizard

The Setup Wizard is a step by step guide for the the initial setup of the Integrator.

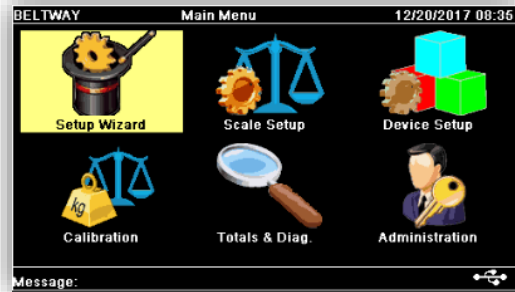

- Number of weigh idlers
(1 for single idler scale and 2 for dual idler scale)
- Load cell capacity found on Load cell assembly label
(45 kg, 100 kg, 200kg, etc. one box will be punched out)



- Idler spacing distance (Measure as shown below)

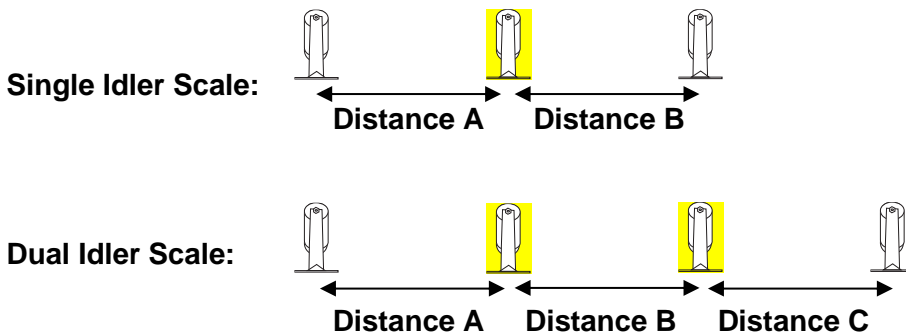

- Conveyor Angle if an automatic angle sensor is not used.
Note: If the conveyor angle is not known, leave the angle at the default of 12 degrees.
- Pulley diameter if using shaft mount speed sensor instead of the wheel speed sensor.

Use the following page to record all the initial scale setup values.

Dealer Contact Information					
Dealer Name:					
Contact Name:					
Contact Phone:					
Contact Email:					
Address:					
City, State, Zip					
Scale Information					
Serial Number:	BWINT-				
Date of Install:					
Conveyor Type:	Stationary <input type="checkbox"/> Stacker <input type="checkbox"/> Mobile (track mounted) <input type="checkbox"/>				
Conveyor Make:					
Conveyor Model:					
Scale Setup Parameters					
Run Mode:					
Number of Idlers:					
Load Cell Size:					
Units:	Distance:		Weight:		Rate-Time:
Conveyor Angle:			Angle Sensor Installed?	YES <input type="checkbox"/>	
Idler Distance:	Dist A:		Dist B:		Dist C:
Speed Sensor:					
Decimal Places:					
I/O Option Board:	Installed <input type="checkbox"/>				
Calibration Parameters					
Trim Factor:		Zero Value:		Belt Length:	
Test Weight Calibration					
Test Weight Amount		Belt Speed		TPH with Test Weight Installed	
Material Test Calibration					
Belt Scale Weights					
Truck Scale Weights					

C. Scale Setup

View or edit scale parameters at the Scale Setup Menu.

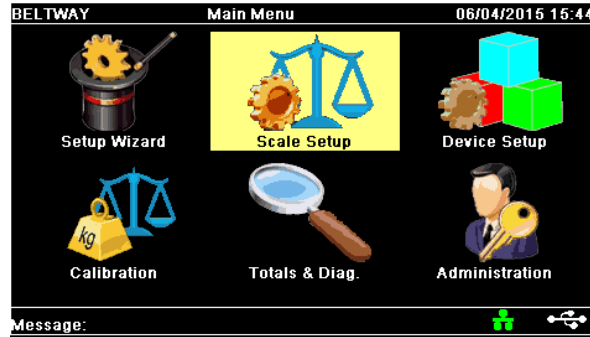

Default Settings

Options

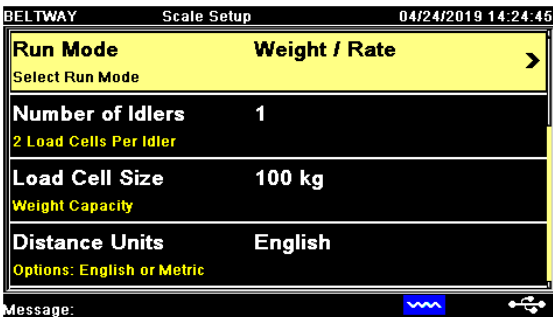

Run Mode: **Weight / Rate, Loadout, Rate Control, Blending**

Number of Idlers: **1,2,3,4**

Load Cell: **45,50,100,150,200,350,500,1000 kg 1000 lb, Custom**

Distance Units: **English, Metric**

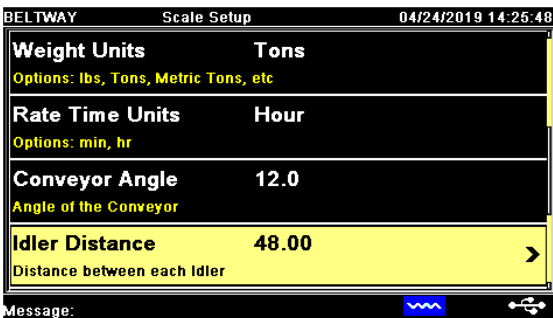

Weight Units: **Tons, Long Tons, Pounds, Tonnes, Kilograms**

Rate Time Units: **Hour, Minute**

Conveyor Angle: **12 (factory default) or install Angle Sensor**

Idler Distance: **48 (factory default)**

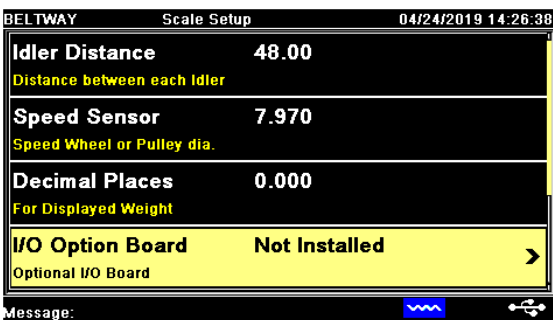

Speed Sensor Wheel Diameter: **7.97**
Pulses per Revolution: **100**

Decimal Places: **0, 0.0, 0.00, 0.000**
(applies to only to accumulated weight)

I/O Board: **Not Installed / Installed**

D. Scale Calibration

Navigate to Main Menu > Calibration

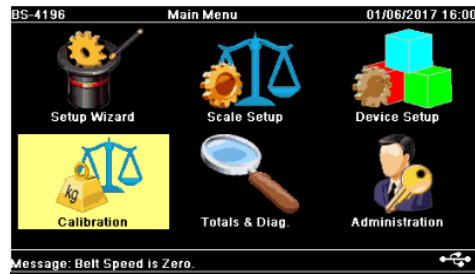

i. Perform Length and Zero (if not completed during the setup wizard)

The Length and Zero measures the belt length and weight of the empty belt.

It must be run once at startup and whenever the belt length changes significantly.

Navigate to **Calibration > Belt Length Cal > Length & Zero** and follow instructions.

If the belt length is less than 60ft and the belt speed is more than 400 fpm, we suggest using a longer Belt length value in the scale. This will improve the stability of the Zero Calibration. Simply allow the belt to run 2 or 3 revolutions during the Length and Zero procedure.

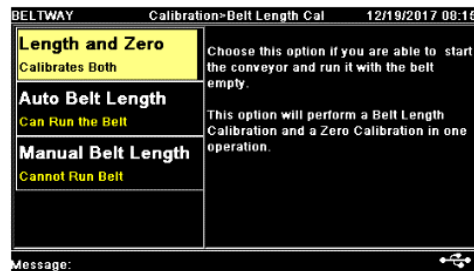
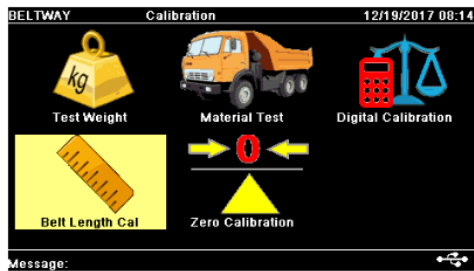

ii. Perform Zero Calibration from Keypad

The Zero Calibration weighs one revolution of the empty belt and calculates a new zero weight. Start the belt running empty and press the Zero Calibration button on the keypad. Follow the instructions on the screen.



- **The Zero Calibration should be performed at least once per day.**
- **It can be repeated multiple times until the accumulated weight hovers up and down slightly with the belt running empty.**
- **The zero calibration should be performed whenever the conveyor is moved.**
- **Scales on transloaders should be calibrated before every truckload.**

iii. Test Weight Calibration

The **Test Weight Calibration** adjusts the **Trim Factor** to properly calibrate the scale. The calibration should be performed at startup and several times per year on a stationary conveyor. A portable conveyor should be calibrated each time it is moved.

Suggested test weight amounts by scale model:					
Model 45 or 50	Model 100 or 150	Model 200	Model 350	Model 500	Model 1000
25-50 lbs.	50-100 lbs.	75-100 lbs.	100-200 lbs.	200+ lbs.	200+ lbs.

Hang the weights directly on the load cells assemblies as shown below. Make sure the weights can't touch the belt or conveyor frame.



Test Bar and Weights

Insert the bar through the holes in the V-Block. The test weight amount must include the bar or other hardware used to hang the weights from the load cells. If the bar weight is unknown, place the bar on the scale first and perform the zero calibration. Then enter the exact weight value for the calibration. At the end, remove the bar and do a second zero calibration.

Test Weight Calibration Notes:

- A test weight calibration is quick and easy, but a repeatable material test is typically more accurate than a test weight calibration.
- A scale may seem properly calibrated with test weights, but may be inaccurate when running material if the idlers and belt are not properly aligned or the belt is too tight.

Navigate to **Main Menu > Calibration > Test Weight**. Enter the test weight amount.

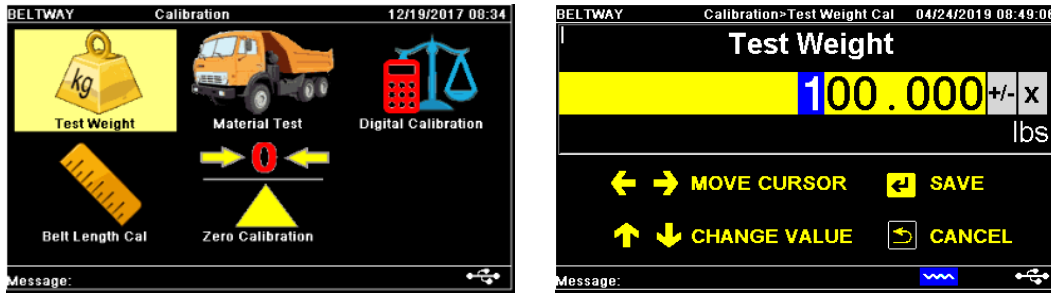

Start the belt running empty and follow the instructions on the screen. The calibration will run for several belt revolutions and then stop. Pay close attention to the Old Trim Factor and New Trim Factor on the **Accept Cal** screen.

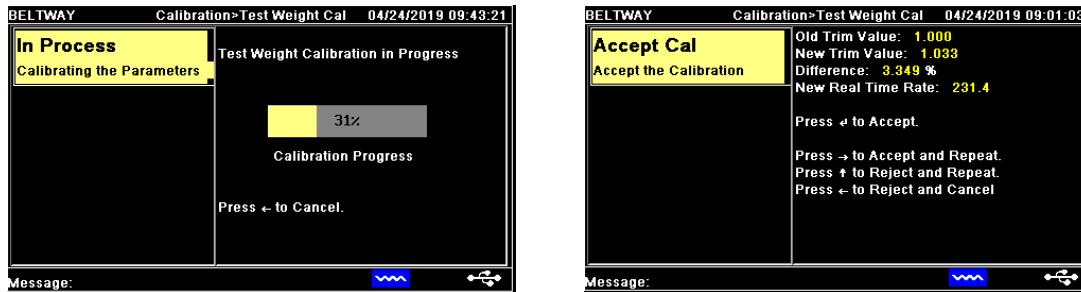

The **Trim Factor** will ideally be between **.90 and 1.10**.

If the **Trim Factor** is close to 1.000, use the following formula to verify the calibration.

$$(\text{Test Weight Amount} / \text{Idler Distance}) * \text{Belt Speed} * 60 / 2000 = \text{Tons Per Hour}$$

Example: (100 lbs. / 4 ft.) * 400 feet per minute * 60 / 2000 = 300 Tons Per Hour

If the **New Trim Factor** is out of range navigate to **Main Menu > Totals & Diag > Live Weight**.



Live Weight shows the current force on the load cells in pounds or kilograms. **Trimmed Live Weight** adjusts the value by the Trim Factor. If the **Live Weight** isn't close to the test weight placed on the scale, then check to be certain that there is nothing interfering with the idler, test weight bar, or load cells. Also, use a platform

scale to accurately measure the test weights out to 2 decimal places. For example, 50.25 pounds. Check all other parameters including model number, idler distance, and angle.

**Repeat the calibration if any parameters were changed.
Record calibration information on pages 40-41.**

iv. Perform Material Test Calibration

The **Material Test Calibration** verifies the belt scale against a certified scale.

The calibration is typically performed with a legal for trade truck scale. It is also possible to do a material test comparison with a loader scale, rail scale, barge draft, or other very accurate weight.

1. Weigh the truck **EMPTY** to get an accurate tare weight.
2. Reset the weight on the belt scale or record the starting weight.
3. Start the test and make sure all material is caught in the truck. Larger tests are better. A minimum of 10 tons per test is recommended.
4. Allow belt to run empty for 10-15 seconds prior to recording the accumulated weight. Complete 3 or more tests in a row without changing anything on the scale.
Run the belt empty and perform a Zero Calibration prior to each material test load.
5. Compare the results to prove the scale is repeatable. **See the example below.**

	Belt Scale	Truck Scale	Difference
Test 1	14.00 tons	11.00 tons	21.43 %
Test 2	10.75 tons	11.25 tons	-4.65 %
Test 3	13.00 tons	13.50 tons	-3.85 %
Test 4	12.00 tons	12.50 tons	-4.17 %

6. Discard any tests that are unreasonably different from the rest. **Test 1 is excluded in the example.**
7. Navigate to **Calibration > Material Test.**

8. Enter the **Belt Scale Weight**.
Add tests 2-4 to calculate Belt Scale Total of 35.75

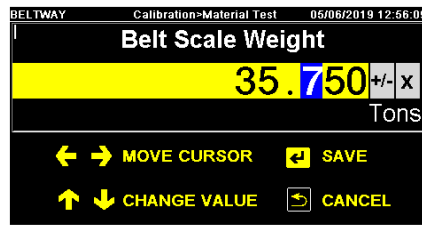

9. Choose the **Certified Units**.
Units in example are Tons

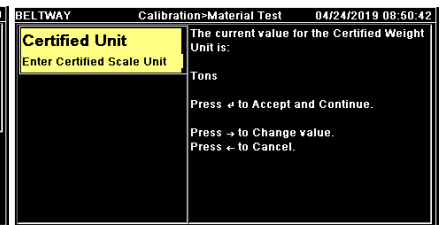

10. Enter the **Certified Weight**.
Add tests 2-4 to calculate Truck Scale Total of 37.25

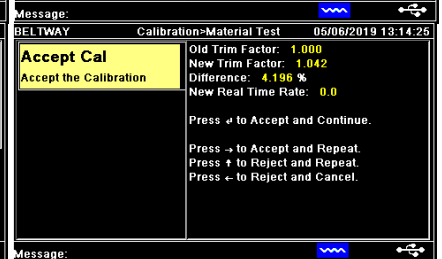
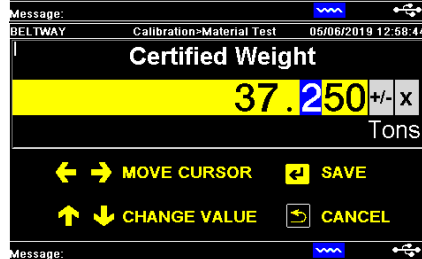

11. Follow the instructions and press **Enter** several times until you reach the **Accept Cal** screen. The **New Trim Factor** will typically be range from **.90 to 1.10**. **The example changes the Trim Factor from 1.000 to 1.042. A 4.2% change in the calibration.** If the trim is out of range make sure the correct weights and units were used.
Reject and Repeat the calibration if incorrect values were entered.

Record calibration information on pages 40-41.

**If multiple truck loads vary greatly
from one to the next then review
troubleshooting procedures and contact tech support.**

v. Digital Calibration

The digital calibration resets the **Trim Factor** to the default of 1.000.
 Navigate to **Calibration > Digital Calibration** and follow the instructions.

E. Totals and Diagnostics

Totals & Diagnostics contains additional scale totals and other scale information.

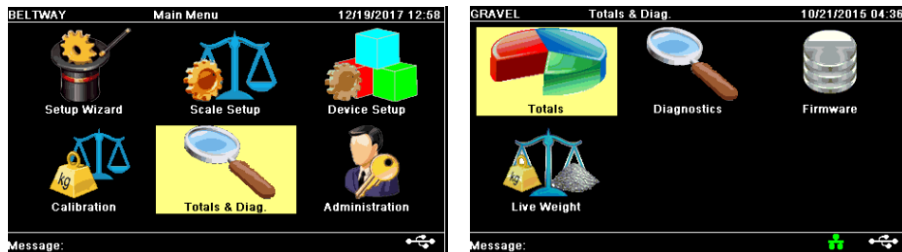

i. Scale Totals

Navigate to **Totals & Diagnostics > Totals**

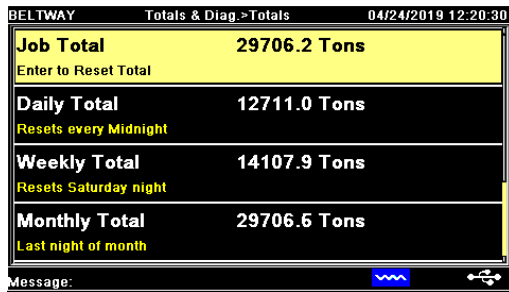

Job Total: Accumulates until it is manually reset.
Press Clear Weight twice to reset the Job Total to 0.
Daily Total: Automatically resets each day.
Weekly Total: Automatically resets each week.
Monthly Total: Automatically resets each month.
Yearly Total: Automatically resets each year.
Master Total: Does **NOT** reset.

ii. Firmware

Navigate to **Totals & Diagnostics > Firmware**

This screen displays the firmware version running on the integrator board.

Contact Belt-Way for all firmware related questions.

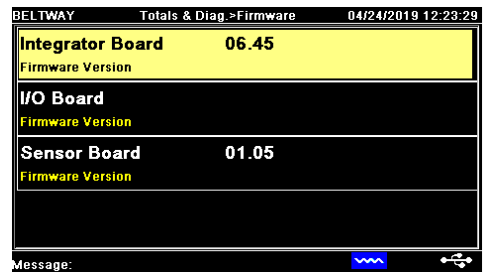

iii. Diagnostics

Navigate to **Totals & Diagnostics > Diagnostics**

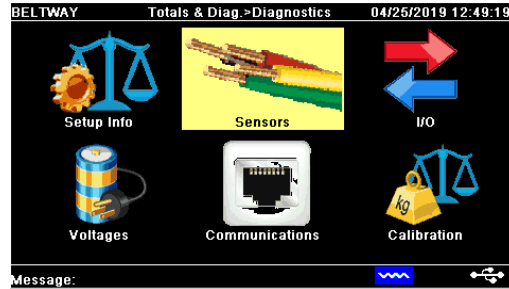
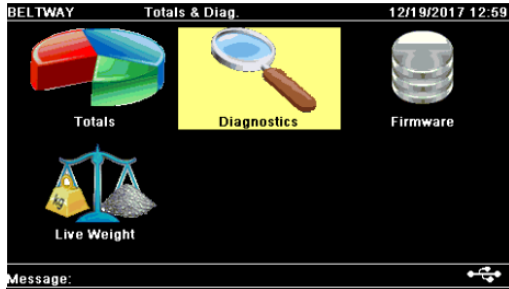

Calibration

Navigate to **Totals & Diagnostics > Diagnostics > Calibration**

- **Trim Factor (Calibration Multiplier)**
Should be close to 1.000
- **Zero Value (Empty Belt Weight)**
Typically, 75 – 150 pounds.
This varies based on belt width, idler spacing, idler weight, etc.
- **Belt length**

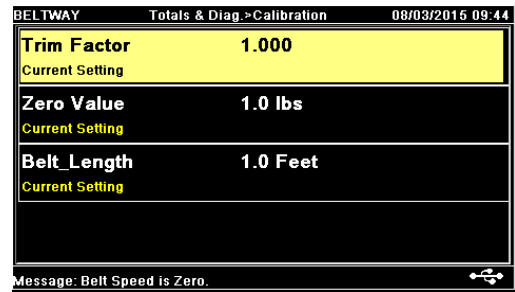

Voltages

Navigate to **Totals & Diagnostics > Diagnostics > Voltages**

- **Load Cell Supply** - Typically 9 - 9.10VDC
- **+5v** - Typically is between 4.95 - 5.10VDC

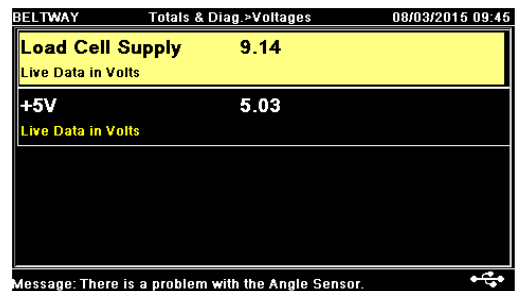

Sensors

Navigate to **Totals & Diagnostics > Diagnostics > Sensors**

- **Load cells 1-8**
- **Speed Sensor**
- **Angle Sensor**

The screenshot shows a diagnostic screen titled 'BELTWAY Totals & Diag > Sensors' with a timestamp of '08/03/2015 09:46'. It displays a table of load cell data:

Load Cell	Value
Load Cell 1	5.2
Live Data in mV	
Load Cell 2	1.8
Live Data in mV	
Load Cell 3	-5.4
Live Data in mV	
Load Cell 4	-8.3
Live Data in mV	

At the bottom of the screen, a message reads: 'Message: Belt Speed is Zero.' There is also a USB icon in the bottom right corner.

Load Cell mV signal diagnostics.

- Each load cell should show **1.0 - 7.0 mV** when the belt is empty.
- The mV reading varies based on the zero value. Review the mechanical installation if there is more than **2.0 mV** difference between load cells.
- **31 mV** is the maximum and is usually caused by a wiring error.
- **Negative values mean the load cell is wired wrong or could be damaged.**
- **Check weighbridge for anything pushing up on the idler.**

Testing the Load Cells

If mV readings are out of range use a volt meter to manually check the load cells.

Measure Actual Excitation Voltage at the Sensor Board

+Sup and -Sup should be **9 - 9.10VDC**

Measure Actual Load Cell mV Signal

Set your meter to DC mV (or DC Volts on auto ranging meter)

Place the **Black** Lead on **White Wire (-SIG)** and **Red** lead on **Green Wire (+SIG)**

The reading should match the integrator.

Measure Load Cell Resistance (Ohms)

Disconnect the load cell from the sensor board.

Set your meter to Ω (OHMS)

Test Supply wires - **Black** and **Red** should measure approximately 420 Ω

Test Signal wires - **White** and **Green** should measure approximately 350 Ω

F. Device Setup

Navigate to **Main Menu > Device Setup**

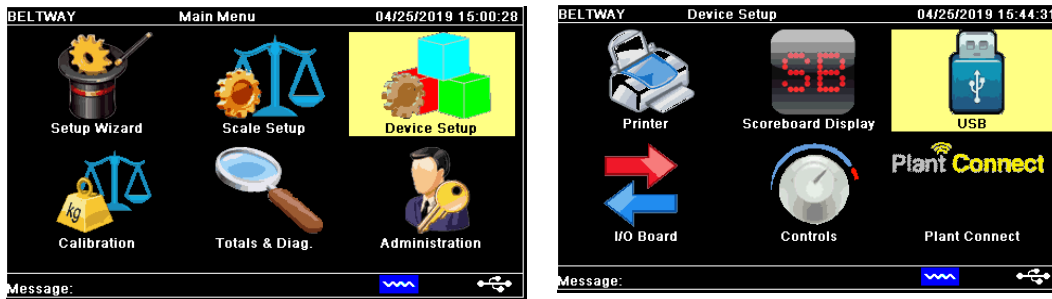

CONTACT BELT-WAY FOR SPECIFIC DOCUMENTATION COVERING THE PRINTER, SCOREBOARD DISPLAY, IO BOARD, AND PLANT CONNECT

USB Data Logging

The integrator saves to a periodic_log.txt file once per minute. It syncs new data to the USB drive once per hour. The data can be manually synced to the USB drive by holding the down arrow for 5 seconds.

Insert the USB into a PC to view the files. Files are stored at [BeltwayScales/Belt Scale/Periodic Logs](#)

Backup & Restore Function

Navigate to **Device Setup > USB > Report Data**

This feature saves the scale's current settings the USB.

It is ideal to create a backup file after the initial scale setup and calibration is complete.

Choose **CREATE BACKUP**. The file is saved on the USB at [Beltway Scales/Belt Scale/Backups](#)

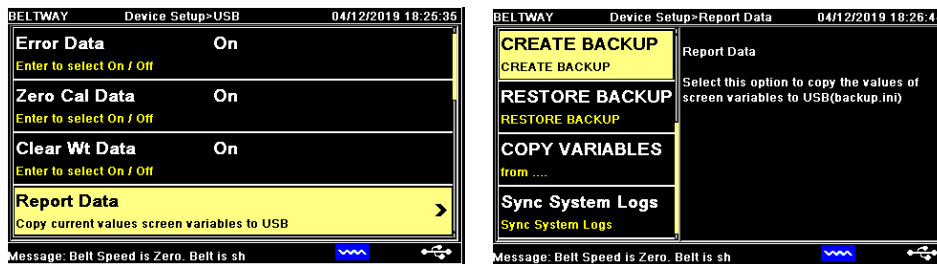

To restore the scale configuration, choose **RESTORE BACKUP** and select the desired backup file.

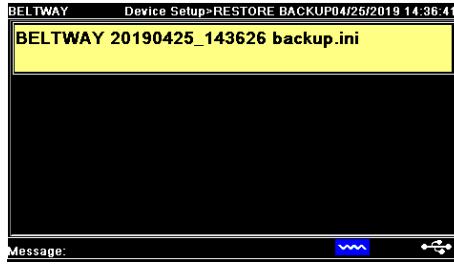
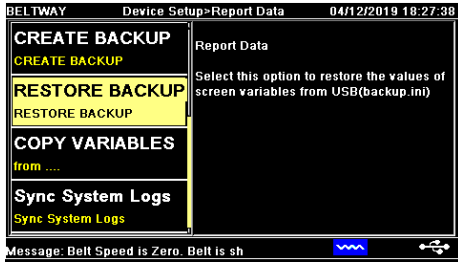

Plant Connect

web-based production monitoring:

Unlimited Scales
Unlimited Users



iPhone / Android App



Historical Data

Realtime Dashboard

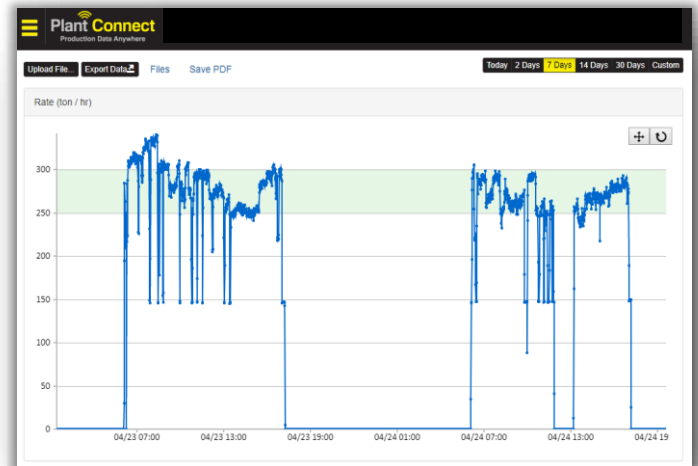

Production Reports

Production Summary Report

Report Date Range:
From: 2019-03-17 To: 2019-03-23
Shift Time: 05:00 To 13:30

Report Created Date: 03-20-2019
Report Created By: aaron.rogers@beltwayscales.com

Location: Crushing Plant

Scale	Production (Ton)	Percent Of Feed	Stopped Belt (Hours)	Black Belt (Hours)	Low Production (Hours)	Optimal Production (Hours)	High Production (Hours)	Belt Run Time (Hours)	Run Time Ave Rate (ton / hr)	Run + Stopped Time Ave Rate (ton / hr)
CV-1	20248.84	100.00	00:00:00	00:00:00	00:00:00	32:46:00	00:00:00	32:46:00	617.96	617.96
CV-2	4079.02	20.14	00:00:00	00:00:00	00:04:41	07:35:00	24:06:19	31:46:00	128.36	128.36
CV-3	4582.3	22.63	00:00:00	00:00:00	31:44:00	00:00:00	00:00:00	31:44:00	144.39	144.39
CV-4	3611.53	17.84	00:00:00	21:11:00	05:47:00	02:25:00	02:23:00	31:46:00	113.01	113.01
Production Total	12272.85		00:00:00	21:11:00	37:35:41	10:00:00	26:29:19	95:16:00	128.58	128.58

Contact Belt-Way for more information about how to sign up!

G. Administration

Navigate to **Main Menu > Administration**

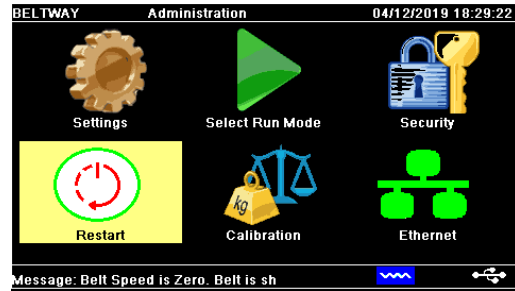
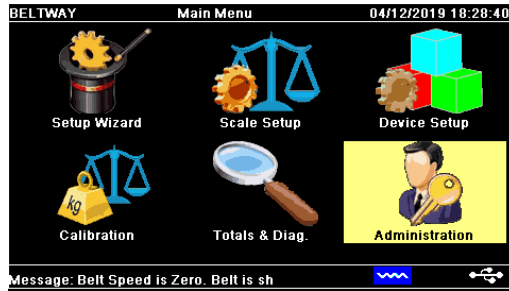

Security

Navigate to **Administration > Security**

Create a password to restrict access certain scale functions.

Any locked item requires the password.

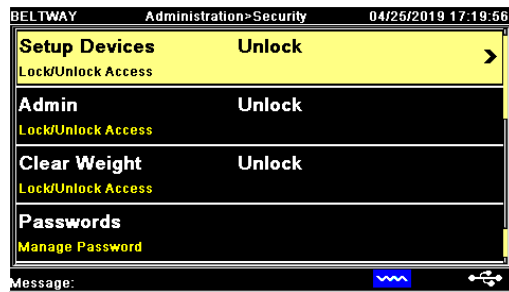

Set the Time and Date

Navigate to **Administration > Settings**

Time must be in 24 hour format.

The Date can be MM/DD/YYYY or DD/MM/YYYY format.

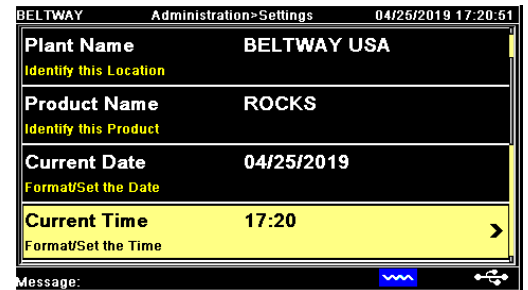

Scale Restart

Navigate to **Administration > Restart**

This feature allows a user to restart the integrator firmware.



Routine Maintenance Checklist

The scale will only perform as well as the surrounding environment allows. Inspect the scale, belt, idlers, etc on a regular basis to ensure all components are functioning properly.

Maintenance Item	Task	Daily	Weekly	Monthly	As Needed
Weighbridge Idlers	Check rollers for flat spots, collapsed bearings and make sure the rollers spin freely.		X		
Scale Idler	Make sure there is no material build up between the Idler and conveyor frame. Make sure the scale idler is not bent or twisted.		X		
Scale Frame	Make sure there is no material build up around the load cell assemblies or mounting pipes.		X		
String Line	Re string line when replacing idlers. The idlers need to be the same type & angle. They also need to be square and equally spaced. +/- 1/16 th Inch				X
Return Rollers	Make sure they are in good condition and in position. They must also be clean & free from any material build up.		X		
Speed Sensor	Check for wear & flat spots on the and ensure that the wheel spins freely. Make sure wheel remains in contact with belt at all times when running.		X		
Belt Condition	Make sure belt is in good condition and repair or replace as needed.			X	
Belt Tension	Make sure belt tension is NOT too tight or loose and that it touches all idlers in the weighbridge.			X	
Belt Tracking	Make sure belt tracking is good, especially across the weighbridge area.			X	
Zero Calibration	Perform a Zero Calibration	X			
Test Weights	Perform a Test Weight Calibration			X	X
Material Test	Perform a Material Calibration test and Adjust.			X	X

Troubleshooting

Belt Speed Problems

If there is no belt speed:

- Confirm the belt is running.
- Confirm the speed sensor wheel is touching the belt and turning.
- Confirm that the wheel is not excessively worn or bouncing.
- Shaft Mount – Check the shaft for pulley shaft damage.

Check Speed Sensor Supply Voltage

- Set Meter to VDC and measure between +5V and (GND) Ground.
- **Check for damaged wires.**
- Set Meter to Ω (OHMS) or Ringer.
- Remove cover from the speed wheel.
- Perform checks for an open circuit or broken wire.
- If the cable is not damaged then the encoder board may be damaged.
- Contact tech support for further assistance.

Angle Sensor Problems

- Compare the angle reading to an external angle finder.
- Manually move the angle sensor up and down to see if the angle changes.
- **Check Angle Sensor Signal on Diagnostics Screen.**
- If angle sensor is connected make sure it is “Installed” in Scale Setup menu.
- Make sure the Arrow on the angle sensor is Pointing UP.
- **Check Angle Sensor Supply Voltage.**
- Supply voltage should be about 5 VDC. Set Meter to VDC and measure between +5V and (GND) on the angle sensor terminal.
- **Check Signal Voltage**
- Set Meter to VDC and measure between SIG A and (GND) on the sensor board.
- The reading should be between 0.01VDC and 4VDC depending on the angle of the conveyor.
- **-45Deg = 0VDC, 0DEG = 2VDC, +45DEG =4VDC**

Power Problems

The integrator requires a minimum of 12 VDC to operate properly. Underpowered AC transformers will not work. We strongly suggest use of the Belt-Way AC power supply.

AC Power Supply Spec:

- Input: 100-240 VAC 50/60 Hz.
- Output: 24VDC, 2.25A Max.

DC Power Source:

- A 12 VDC battery may be used to power the scale, but it must be in good condition.
- The alternator must function properly to avoid damage to the integrator.
- Low power will cause the integrator screen to blink or go white.
- A toggle switch should be installed so integrator can be turned off prior to startup and shut down.

Error Messages

No Comms with Sensor Board

- Check supply voltage. The Sensor board drops out below 12 VDC.
- Unplug SENSOR PWR and SEN RS485 INTERFACE ribbon cables if using a junction box.
- Check the cable running from integrator to the junction box.
- Test for 24 VDC on SNSR PWR and GND.
- Check fuses.

No belt speed

- Follow speed sensor trouble shooting procedure.

No IO Board

- IO board is not installed. Change setting in Scale Setup menu.
- Check ribbon cable from integrator board to IO board.

Bad Load Cell

- Check wiring.
- Follow Load Cell testing procedure.

Calibration Log #1					
Calibration Log #1		Calibrated by:			
Zero Calibration					
Previous Zero Value:		New Zero Value:			
Test Weight Calibration					
Test Weight Amount:		Belt Speed:			
TPH with Test Weight Installed:		Calculated TPH:			
Old Trim Factor:		New Trim Factor:			
Material Test Calibration					
	Test 1	Test 2	Test 3	Test 4	Test 5
Belt Scale Weights					
Truck Scale Weights					
Old Trim Factor:			New Trim Factor:		

Calibration Log #2					
Zero Calibration					
Previous Zero Value:		New Zero Value:			
Test Weight Calibration					
Test Weight Amount:		Belt Speed:			
TPH with Test Weight Installed:		Calculated TPH:			
Old Trim Factor:		New Trim Factor:			
Material Test Calibration					
	Test 1	Test 2	Test 3	Test 4	Test 5
Belt Scale Weights					
Truck Scale Weights					
Old Trim Factor:			New Trim Factor:		

Calibration Logs					
Zero Calibration					
Previous Zero Value:		New Zero Value:			
Test Weight Calibration					
Test Weight Amount:		Belt Speed:			
TPH with Test Weight Installed:		Calculated TPH:			
Old Trim Factor:		New Trim Factor:			
Material Test Calibration					
	Test 1	Test 2	Test 3	Test 4	Test 5
Belt Scale Weights					
Truck Scale Weights					
Old Trim Factor:			New Trim Factor:		

Calibration Logs					
Zero Calibration					
Previous Zero Value:		New Zero Value:			
Test Weight Calibration					
Test Weight Amount:		Belt Speed:			
TPH with Test Weight Installed:		Calculated TPH:			
Old Trim Factor:		New Trim Factor:			
Material Test Calibration					
	Test 1	Test 2	Test 3	Test 4	Test 5
Belt Scale Weights					
Truck Scale Weights					
Old Trim Factor:			New Trim Factor:		

Conveyor Belt Scale Product Warranty

Belt-Way Scales, a division of Cardinal Scale Manufacturing Company, warrants the equipment we manufacture against defects in material and workmanship for a period of one year from the original date of purchase.

1. This warranty applies only to the original purchaser. The warranty does not apply to equipment that has been tampered with, defaced, damaged, or had repairs or modifications not authorized by Belt-Way / Cardinal or has had the serial number altered, defaced or removed.
2. This warranty is not applicable to equipment that has not been grounded in accordance with manufacturer's recommendations.
3. This equipment must be installed and continuously maintained by an authorized Belt-Way / Cardinal dealer.
4. This warranty does not apply to equipment damaged in transit. Claims for such damage must be made with the responsible freight carrier in accordance with freight carrier regulations.
5. Warranty term begins with date of shipment from Belt-Way.

EXCLUSIONS

- A. This warranty does not include replacement of consumable or expendable parts. The warranty does not apply to any item that has been damaged due to unusual wear, abuse, improper line voltage, overloading, theft, fire, water, prolonged storage or exposure while in purchaser's possession or acts of God unless otherwise stated herein.
- B. This warranty does not apply to peripheral equipment not manufactured by Cardinal. This equipment will normally be covered by the equipment manufacturer's warranty.
- C. This warranty sets forth the extent of our liability for breach of any warranty or deficiency in connection with the sale or use of our product. Cardinal will not be liable for consequential damages of any nature, including but not limited to loss of profit, delays or expenses, whether based on tort or contract. Cardinal reserves the right to incorporate improvements in material and design without notice and is not obligated to incorporate said improvements in equipment previously manufactured.
- D. This warranty is in lieu of all other warranties expressed or implied including any warranty that extends beyond the description of the product including any warranty of merchantability or fitness for a particular purpose. This warranty covers only those Cardinal products installed in the forty-eight contiguous United States and Canada.
- E. This warranty does not cover paint coatings due to the variety of environmental conditions.
- F. Do not cut load cell cables on load cells returned for credit or warranty replacement. Cutting the cable will void the warranty.

Limitations and Disclaimer

BELT-WAY SCALES MAKES NO REPRESENTATION OR WARRANTY OF ANY OTHER KIND, EXPRESS OR IMPLIED, WITH RESPECT TO THE PRODUCTS, WHETHER AS TO MERCHANTABILITY, FITNESS FOR A PARTICULAR PURPOSE OR ANY OTHER MATTER, ANY SUCH WARRANTIES BEING HEREBY EXPRESSLY EXCLUDED. BELT-WAY SCALES, INC. DOES NOT AUTHORIZE ANYONE TO MAKE ANY OTHER WARRANTY EXCEPT AS STATED HEREIN.

Exclusion of Consequential Damages

BELT-WAY SCALES, INC. SHALL IN NO EVENT BE RESPONSIBLE FOR SPECIAL, INCIDENTAL OR CONSEQUENTIAL DAMAGES CAUSED BY ANY PRODUCT SOLD HEREUNDER, WHETHER ON THEORIES OF BREACH OF EXPRESS OR IMPLIED WARRANTIES UNDER THE UNIFORM COMMERCIAL CODE, STRICT LIABILITY, NEGLIGENCE OR ANY OTHER LEGAL THEORY REGARDLESS OF WHETHER THE LOSS RESULTED FROM ANY GENERAL OR PARTICULAR REQUIREMENT OR NEED WHICH BELT-WAY SCALES, INC. KNEW ABOUT OR HAD REASON TO KNOW ABOUT AT THE TIME OF THE SALE OF SUCH PRODUCTS.

BELT-WAY is a registered trademark of Belt-Way Scales, Inc.
Covered by U.S. PATENT 5,696,354

Belt-Way Scales, Inc.
102 Daugherty
Webb City, Missouri 64870 USA
Phone: (815) 625-5573
sales@beltwayscales.com
www.beltwayscales.com